

Centre Number	Candidate Number	Name
---------------	------------------	------

CAMBRIDGE INTERNATIONAL EXAMINATIONS
International General Certificate of Secondary Education

CO-ORDINATED SCIENCES

0654/02

Paper 2

October/November 2003

2 hours

Candidates answer on the Question Paper.
No Additional Materials are required.

READ THESE INSTRUCTIONS FIRST

Write your Centre number, candidate number and name on all the work you hand in.
Write in dark blue or black pen in the spaces provided on the Question Paper.
You may use a soft pencil for any diagrams, graphs, tables or rough working.
Do not use staples, paper clips, highlighters, glue or correction fluid.

Answer **all** questions.

At the end of the examination, fasten all your work securely together.

The number of marks is given in brackets [] at the end of each question or part question.

A copy of the Periodic Table is printed on page 20.

For Examiner's Use	
1	
2	
3	
4	
5	
6	
7	
8	
9	
10	
11	
Total	

If you have been given a label, look at the details. If any details are incorrect or missing, please fill in your correct details in the space given at the top of this page.

Stick your personal label here, if provided.

1 Fig. 1.1 shows some cells that are found in the lining of the trachea (windpipe).

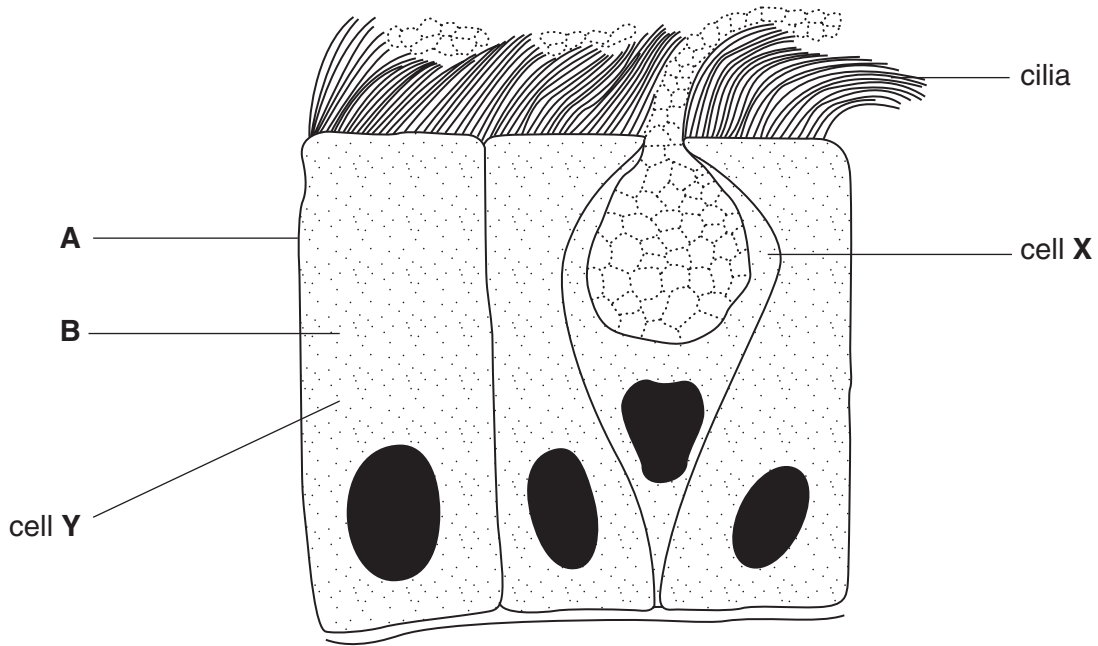

Fig. 1.1

(a) (i) Name the parts of cell Y that are labelled A and B.

A

B

[2]

(ii) How can you tell that cell Y is an animal cell and not a plant cell?

.....
.....[2]

(b) Describe the function of cell X.

.....
.....
.....[2]

(c) When a person smokes a cigarette, the cilia stop working.

Explain how this can affect the smoker's breathing system.

.....
.....
.....
.....[3]

- 2 Fig. 2.1 shows an electrical circuit set up to measure the current going through a lamp and the voltage across it.

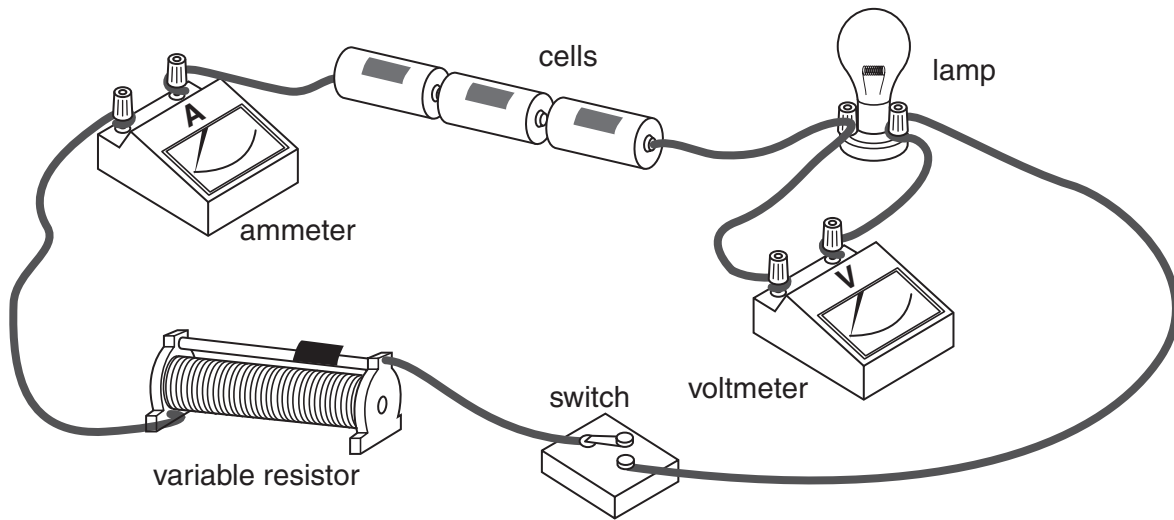

Fig. 2.1

- (a) Draw the circuit diagram for the apparatus used in this experiment.

[3]

- (b) State **one** way to increase the current in this circuit.

.....[1]

- (c) If the resistance of the variable resistor is increased, state and explain what happens to

(i) the voltmeter reading,

.....

(ii) the ammeter reading,

.....

(iii) the brightness of the lamp.

.....

[3]

- 3 (a) Many metals react with dilute hydrochloric acid. A general word equation reaction is shown below.

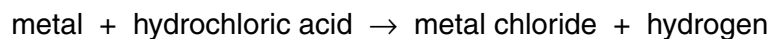

- (i) Describe the test for hydrogen.

.....
[2]

- (ii) The apparatus shown in Fig. 3.1 can be used to investigate the rate of reaction between hydrochloric acid and a metal. To start the reaction, the flask is tilted to mix the reactants.

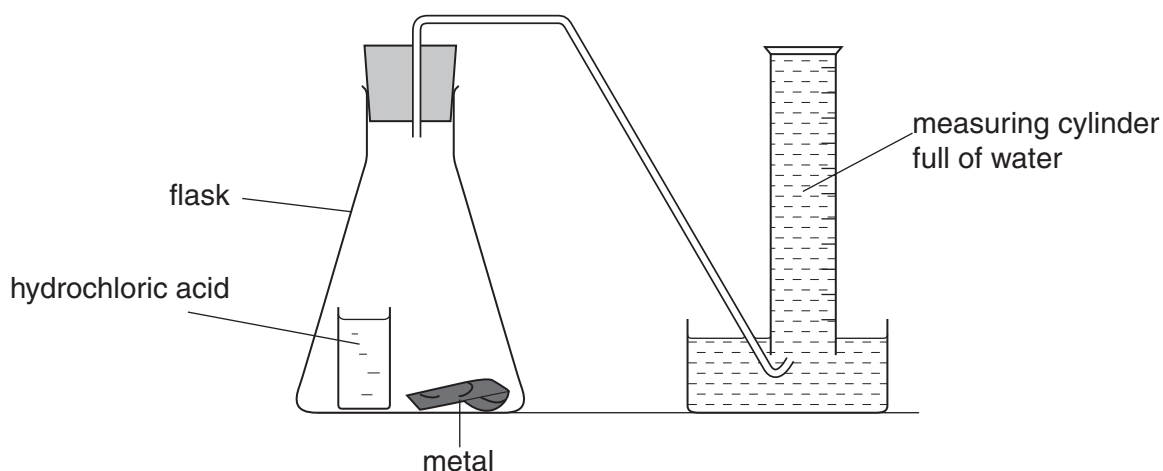

Fig. 3.1

Describe how the apparatus could be used to compare the rates of reaction between hydrochloric acid and two metals **A** and **B**.

.....

[3]

(b) The metals shown below are listed in order of their chemical reactivity.

magnesium (most reactive)
zinc
iron
tin
copper

A student carried out an experiment to investigate rusting of iron nails. He joined small pieces of different metals to identical iron nails and placed the nails in open test-tubes which contained a little water. The observations that the student made some days later are shown in Fig. 3.2.

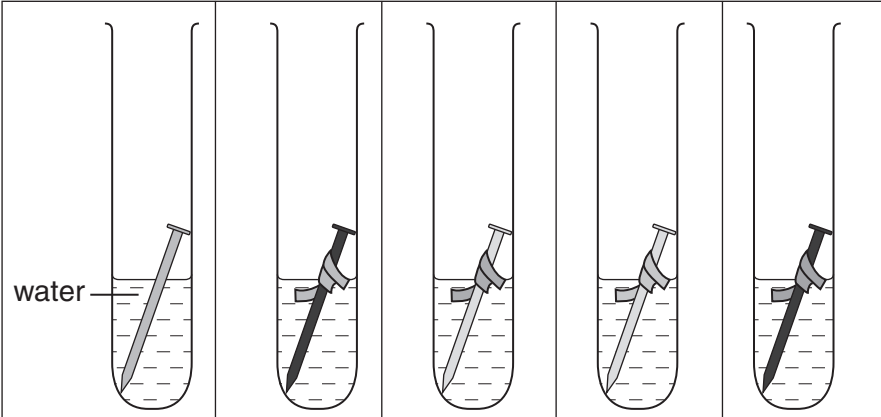

					
metal joined to nail	none (control)	tin	magnesium	zinc	copper
observation	slight rust	heavy rust	no rust	no rust	heavy rust

Fig. 3.2

What conclusions could the student draw from these observations?

.....

.....

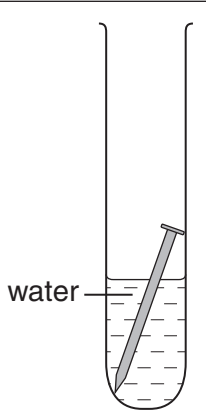
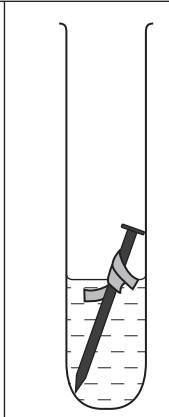
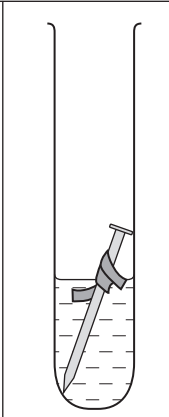
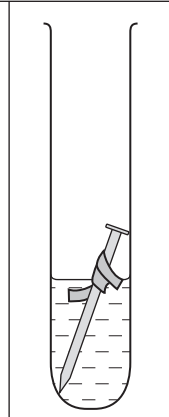
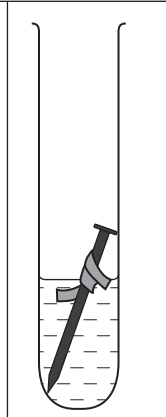
.....

.....[2]

- 4 (a) A bat locates a moth by emitting a pulse of ultrasound as shown in Fig. 4.1. The pulse takes 0.2 seconds to reach the moth and return to the bat after reflection. The speed of ultrasound waves in air is 330 m/s.

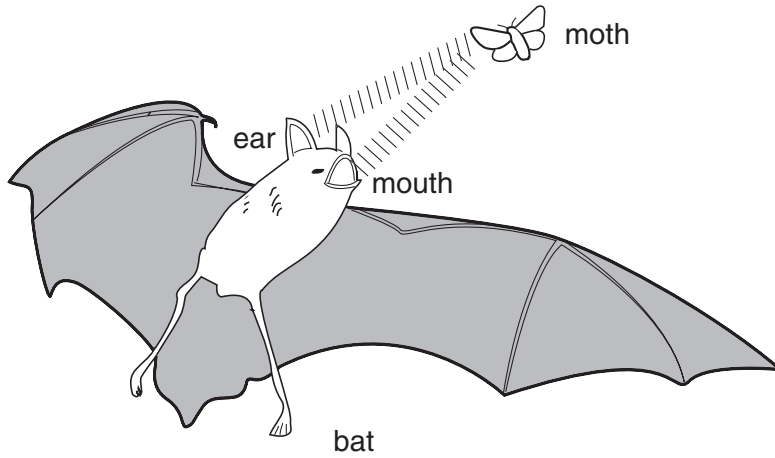

Fig. 4.1

- (i) Calculate the distance between the moth and the bat. State the formula that you use and show your working.

formula

working

.....m [3]

- (ii) Ultrasound waves travel through the air like sound waves. Explain how these waves travel.

.....

.....

.....[2]

- (iii) Ultrasound waves from a bat have the same amplitude as the sound waves on the oscilloscope trace in Fig. 4.2, but a higher frequency.

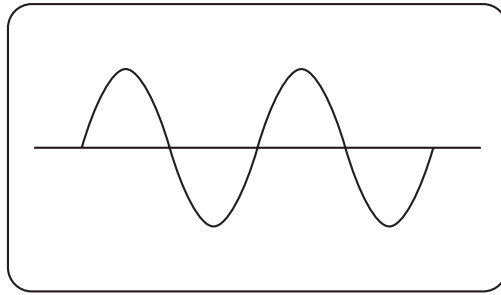

Fig. 4.2

On Fig. 4.3, sketch the trace that would be produced by the ultrasound waves from a bat.



Fig. 4.3

[2]

- (b) A locust of mass 2.5 g jumps at a speed of 3 m/s. Calculate the kinetic energy of the locust at this moment. State the formula that you use and show your working.

formula

working

.....J [3]

5 Whenever a person eats food, small amounts of the food are left on and between the teeth. Bacteria in the mouth feed on this, producing acids.

(a) Fig. 5.1 shows the pH in a boy's mouth from the time that he got up to when he went to bed.

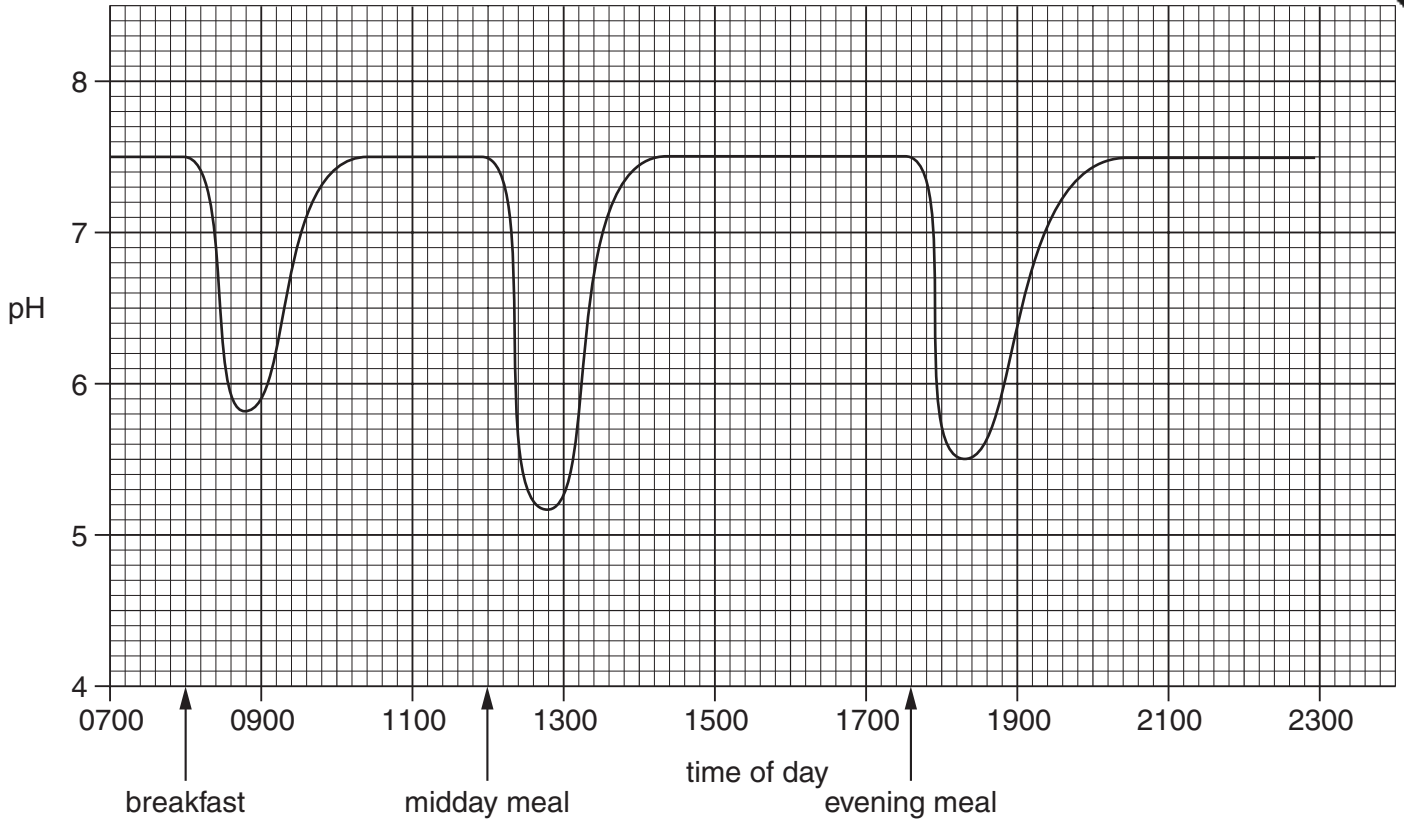

Fig. 5.1

(i) What is the normal pH in the boy's mouth?

.....

[1]

(ii) Explain why the pH dropped just after midday.

.....

.....

.....[2]

- (iii) Toothpastes contain a weak alkali. On Fig. 5.1, draw a line to show what the pH of the mouth might be between 08:00 and 12:00 if the boy had cleaned his teeth immediately after breakfast.
- (iv) With reference to Fig. 5.1 and your own knowledge, explain how cleaning your teeth can prevent tooth decay.

.....

.....

.....

.....

.....[3]

(b) Fig. 5.2 shows the teeth on one side of a person's lower jaw.

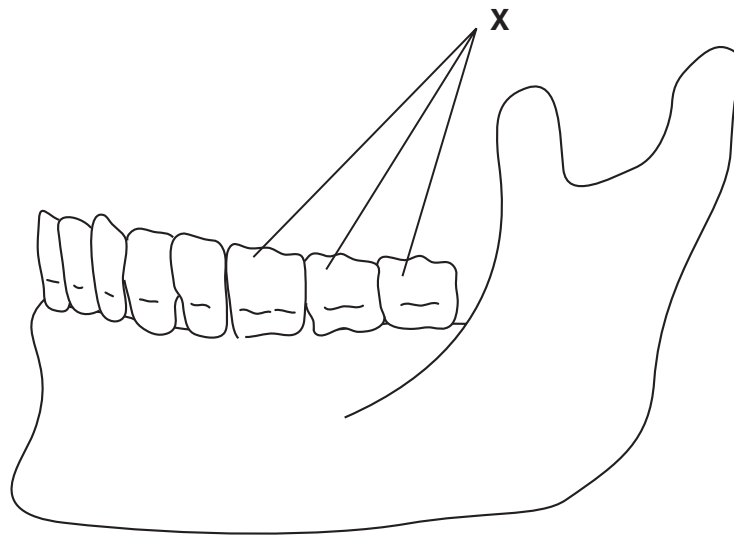

Fig. 5.2

(i) On Fig. 5.2, label an incisor tooth. [1]

(ii) Describe the function of the teeth labelled X.

.....

.....

.....[2]

(iii) Tooth decay is more common in the teeth labelled X than in other teeth. Suggest why this is so.

.....

.....

.....[2]

- 6 Silicon is an important element used to make microchips for electronic devices. Silicon is obtained from silicon dioxide, SiO_2 , found in the Earth's crust.

(a) (i) Name a **non-metallic** element in the same period of the Periodic Table as silicon.

.....[1]

(ii) Name a **metallic** element in the same group of the Periodic Table as silicon.

.....[1]

(iii) State the number of electrons in the outer shell of a silicon atom. Explain how you obtained your answer.

.....

.....

.....[2]

- (b) Glass is made by melting a mixture of silicon dioxide and metal oxides. Two mixtures, **A** and **B**, used to make glass are shown below.

mixture A	mixture B
silicon dioxide	silicon dioxide
calcium oxide	calcium oxide
sodium oxide	sodium oxide
	iron oxide

- (i) Suggest and explain a visible difference in the appearance of the two types of glass made from these mixtures.

.....

.....

.....[2]

- (ii) Underline **two** phrases in the following list that correctly describe the structure of glass.

disorderly arrangement of atoms

atoms regularly arranged

simple molecules

giant structure

[2]

- (c) The raw materials used to make glass have to be extracted from the Earth. In many countries much waste glass is re-cycled. Fig. 6.1 shows some information about the energy needed to produce one kilogram of new glass.

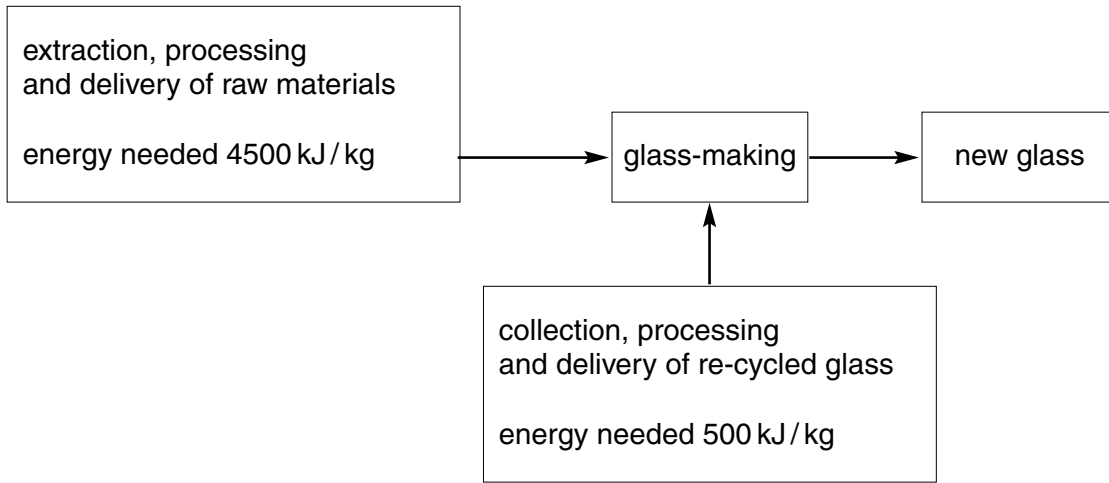

Fig. 6.1

Suggest two advantages of re-cycling waste glass.

- 1
 - 2
- [2]

- 7 (a) Fig. 7.1 shows what happens to rays of white light that are shone at two objects, **A** and **B**.

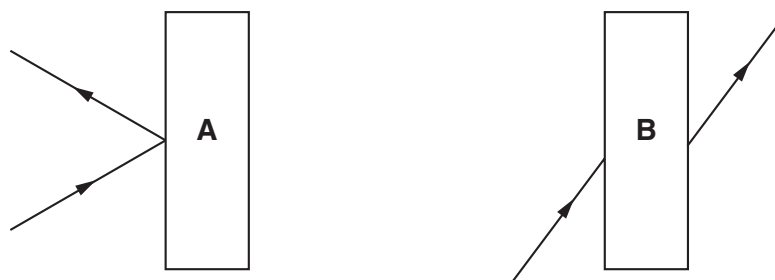

Fig. 7.1

Suggest what objects **A** and **B** might be. Explain your answers.

A

.....

.....

B

.....

.....[4]

- (b) Fig. 7.2 shows a ray of light entering an optical fibre.

Complete the diagram in Fig. 7.2 to show what happens to the ray.

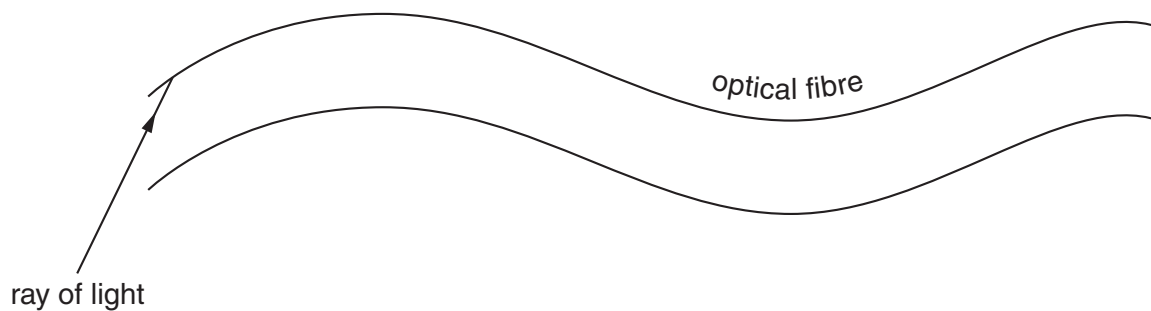

Fig. 7.2

[3]

8 To the people of ancient Greece the word *element* meant earth, air, fire or water.

- (a) (i) Which of the ancient Greek "elements" would be described today as
 a compound,
 a gaseous mixture,
 evidence of a chemical reaction? [3]

(ii) Use an example of your choice to explain the meaning of the term *element* as it is used in modern Chemistry.

example

meaning

.....

.....[2]

(b) The people of ancient Greece used the word *atom* to describe a tiny particle that could not be broken into anything smaller.

Fig. 8.1 shows a diagram of an atom as it is understood today.

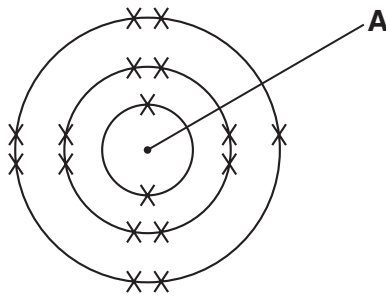

Fig. 8.1

(i) Name the particles present in part A.
[2]

(ii) Name the particle represented by the symbol X
[1]

(iii) Describe briefly what happens when the atom shown in Fig. 8.1 changes into an ion.

.....

.....[1]

9 (a) Complete the **word** equation for photosynthesis.

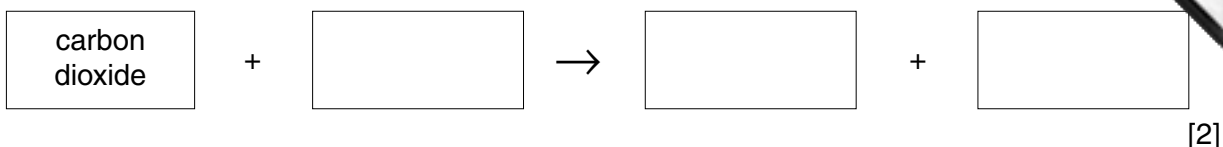

(b) Describe the role of chlorophyll in photosynthesis.

.....

.....

.....[2]

(c) Some of the substances that are made in photosynthesis are converted into a sugar called sucrose. The sucrose is transported around the plant.

(i) Name the tissue in which sucrose is transported in the plant.

.....[1]

(ii) Some of the sucrose is transported to the flowers of the plant.

Suggest and explain **one** reason why flowers need sugar.

.....

.....

.....[2]

(d) (i) With reference to the photosynthesis equation in (a), explain why deforestation could contribute to global warming.

.....

.....

.....

.....

.....[3]

(ii) Describe **one** other way in which deforestation can endanger living organisms.

.....

.....

.....[2]

Turn over for Question 10

10 A skier is pulled up a mountain slope by a cable as shown in Fig. 10.1.

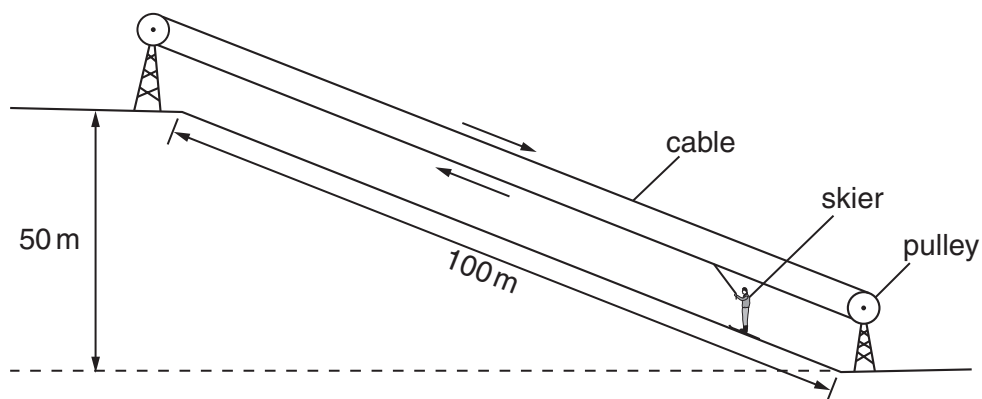

Fig. 10.1

(a) The skier weighs 650 N. She travels 100 m along the slope and rises a vertical height of 50 m.

(i) Calculate the work done in lifting the skier to the top of the slope. You should ignore work done against friction.
State the formula that you use and show your working.

formula

working

.....J [3]

(ii) What form of energy did the skier gain by travelling to the top of the slope?

.....[1]

- (b) Skiers use a stick in each hand to help control their motion. The sticks work best when they only go a few centimetres into the snow.

Fig. 10.2 shows a skier using ski sticks.

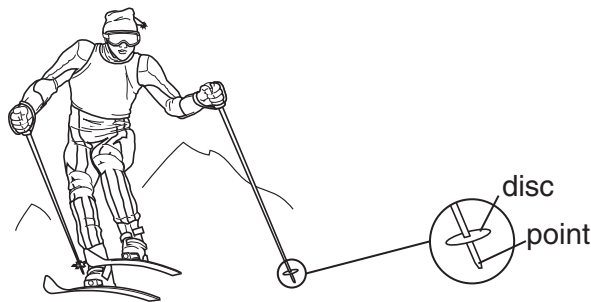

Fig. 10.2

Explain, using the terms pressure, force and area,

- (i) why the ski stick has a pointed end,

.....

[2]

- (ii) why the stick has a disc a few centimetres above the pointed end.

.....

[2]

- (c) Why does the skier keep the lower surface of her skis smooth and well polished?

.....
[1]

11 Limestone is a rock containing calcium carbonate. Limestone may suffer both physical and chemical weathering.

(a) Describe **one** process that causes the **physical** weathering of limestone.

.....

[2]

(b) Rainwater reacts with limestone to form a solution of calcium hydrogencarbonate. This causes the water to become hard.

(i) State two disadvantages of hard water.

1

 2
[2]

(ii) State **one** method of softening hard water containing calcium hydrogencarbonate.

.....
[1]

(c) Fig. 11.1 shows a simplified diagram of a lime kiln which is used to convert calcium carbonate into calcium oxide.

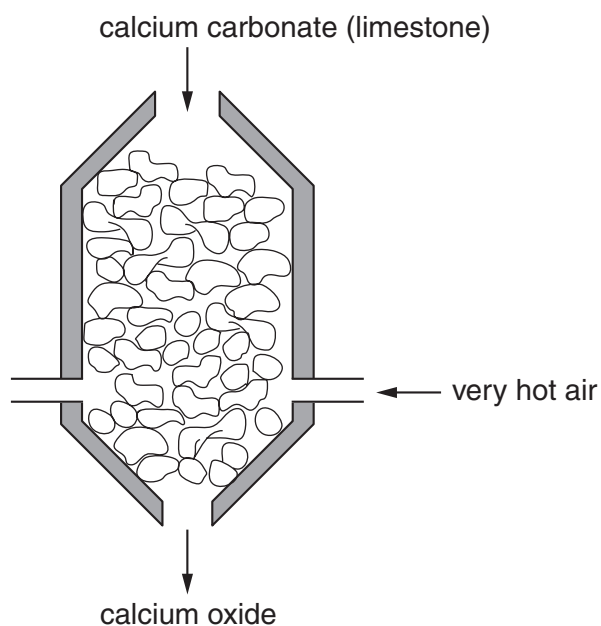
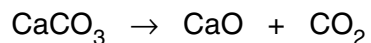

Fig. 11.1

The balanced equation for the reaction in the lime kiln is



- (i) Name the type of chemical reaction that produces calcium oxide in the lime kiln.

.....[1]

- (ii) Describe briefly how dilute hydrochloric acid could be used to show that a rock contains a carbonate.

.....

.....

.....[2]

DATA SHEET
The Periodic Table of the Elements

		Group																																		
I	II	III	IV	V	VI	VII	O																													
7 Li Lithium 3	9 Be Beryllium 4	<table border="1" style="width: 100%; border-collapse: collapse; text-align: center;"> <tr> <td>1 H Hydrogen 1</td> <td colspan="10"></td> </tr> <tr> <td>4 He Helium 2</td> <td colspan="10"></td> </tr> </table>										1 H Hydrogen 1											4 He Helium 2											20 Ne Neon 10		
1 H Hydrogen 1																																				
4 He Helium 2																																				
23 Na Sodium 11	24 Mg Magnesium 12	11 B Boron 5	12 C Carbon 6	14 N Nitrogen 7	16 O Oxygen 8	19 F Fluorine 9	35.5 Cl Chlorine 17	40 Ar Argon 18																												
39 K Potassium 19	40 Ca Calcium 20	27 Al Aluminium 13	28 Si Silicon 14	31 P Phosphorus 15	32 S Sulphur 16	33 Se Selenium 34	79 Br Bromine 35	84 Kr Krypton 36																												
85 Rb Rubidium 37	88 Sr Strontium 38	70 Ga Gallium 31	73 Ge Germanium 32	75 As Arsenic 33	76 Se Selenium 34	112 Cd Cadmium 48	127 I Iodine 53	131 Xe Xenon 54																												
133 Cs Caesium 55	137 Ba Barium 56	59 Co Cobalt 27	58 Ni Nickel 28	103 Rh Rhodium 45	106 Pd Palladium 46	108 Ag Silver 47	209 Bi Bismuth 83	207 Pb Lead 82																												
226 Ra Radium 88	227 Ac Actinium 89	55 Mn Manganese 25	56 Fe Iron 26	101 Ru Ruthenium 44	101 Rh Rhodium 45	190 Os Osmium 76	204 Tl Thallium 81	201 Hg Mercury 80																												
<table border="1" style="width: 100%; border-collapse: collapse; text-align: center;"> <tr> <td>140 Ce Cerium 58</td> <td>141 Pr Praseodymium 59</td> <td>144 Nd Neodymium 60</td> <td>150 Sm Samarium 62</td> <td>152 Eu Europium 63</td> <td>157 Gd Gadolinium 64</td> <td>162 Dy Dysprosium 66</td> <td>165 Ho Holmium 67</td> <td>167 Er Erbium 68</td> <td>169 Tm Thulium 69</td> <td>173 Yb Ytterbium 70</td> <td>175 Lu Lutetium 71</td> </tr> <tr> <td>232 Th Thorium 90</td> <td>238 U Uranium 92</td> <td>91 Pa Protactinium 91</td> <td>93 Np Neptunium 93</td> <td>94 Pu Plutonium 94</td> <td>95 Am Americium 95</td> <td>96 Cm Curium 96</td> <td>97 Bk Berkelium 97</td> <td>98 Cf Californium 98</td> <td>99 Es Einsteinium 99</td> <td>100 Fm Fermium 100</td> <td>101 Md Mendelevium 101</td> <td>102 No Nobelium 102</td> </tr> </table>												140 Ce Cerium 58	141 Pr Praseodymium 59	144 Nd Neodymium 60	150 Sm Samarium 62	152 Eu Europium 63	157 Gd Gadolinium 64	162 Dy Dysprosium 66	165 Ho Holmium 67	167 Er Erbium 68	169 Tm Thulium 69	173 Yb Ytterbium 70	175 Lu Lutetium 71	232 Th Thorium 90	238 U Uranium 92	91 Pa Protactinium 91	93 Np Neptunium 93	94 Pu Plutonium 94	95 Am Americium 95	96 Cm Curium 96	97 Bk Berkelium 97	98 Cf Californium 98	99 Es Einsteinium 99	100 Fm Fermium 100	101 Md Mendelevium 101	102 No Nobelium 102
140 Ce Cerium 58	141 Pr Praseodymium 59	144 Nd Neodymium 60	150 Sm Samarium 62	152 Eu Europium 63	157 Gd Gadolinium 64	162 Dy Dysprosium 66	165 Ho Holmium 67	167 Er Erbium 68	169 Tm Thulium 69	173 Yb Ytterbium 70	175 Lu Lutetium 71																									
232 Th Thorium 90	238 U Uranium 92	91 Pa Protactinium 91	93 Np Neptunium 93	94 Pu Plutonium 94	95 Am Americium 95	96 Cm Curium 96	97 Bk Berkelium 97	98 Cf Californium 98	99 Es Einsteinium 99	100 Fm Fermium 100	101 Md Mendelevium 101	102 No Nobelium 102																								

3-71 Lanthanoid series
0-103 Actinoid series

a = relative atomic mass
X = atomic symbol
b = proton (atomic) number

The volume of one mole of any gas is 24 dm³ at room temperature and pressure (r.t.p.).